

# PowerSno™

## Universal CO<sub>2</sub> Spray Treatment System



PowerSno™  
Vector Pro USTS  
Universal CO<sub>2</sub> Spray Treatment System

- 💡 All-In-One CO<sub>2</sub> Spray Treatment for Precision Cleaning and Machining Applications
- 💡 Use Anywhere – On-the-Bench, On-the-Line, On-the-Robot, or In-the-Tool
- 💡 Simple Adjustment and Instant On/Off Operation, Adaptable and Customizable, and 100% Dry
- 💡 Quickly and Consistently Remove Surface Particles, Ionics, Thin Films, Nonvolatile Residues (NVR), and Cutting Tool Heat
- 💡 Superior Cost-of-Operation (CoO) and Performance as Compared to Conventional CO<sub>2</sub> Spray Systems
- 💡 Footswitch (Standard), Spray Trigger, and Remote Machine-Robot Actuation
- 💡 Several Micronizer™ Spray Applicator Options
- 💡 Expandable – Satellite MicroSno™ Cleaning Modules for Remote Operation

## FEATURES

The **PowerSno™** Universal CO<sub>2</sub> Spray Treatment System (USTS) is an economical yet extremely versatile and powerful precision cleaning or machining fluid tool. Using the latest CO<sub>2</sub> Composite Spray™ technology, the **PowerSno™** generates an energetic cleaning spray or cooling-lubricating vapor comprising pressure-regulated compressed air or nitrogen gas, containing micronized CO<sub>2</sub> particles to efficiently remove contaminants from any manufactured surface or cutting tool. The **PowerSno™** provides a 100% dry spray or vapor treatment - *On-the-Bench, On-the-Line, On-the-Robot, or In-the-Tool*.

**PowerSno™** USTS CO<sub>2</sub> spray treatment for a variety of manufacturing processes, including mechanical assembly, machining, grinding, sanding, polishing, adhesive bonding, welding, coating, and inspection, among others. Manufacturing contaminants, such as hydrocarbon films, fine particles, ionic residues, nonvolatile residues (NVR), and machining heat, are efficiently removed from surfaces.

The **PowerSno™** USTS comprises a high-performance spray generator with the option of a single coaxial spray (standard) or a high-productivity CO<sub>2</sub> composite spray applicator. The **PowerSno™** USTS is fully expandable with several equipment options and accessories, including CO<sub>2</sub> purification, cartesian or collaborative benchtop robots, treatment cabinet, atmospheric plasma surface treatment system, and **LightSPEC™** Spray Quality Monitoring (SQM) system. The **PowerSno™** spray is simply actuated using a footswitch (standard), spray trigger, or by remote machine (or robot) relay closure.

## SPECIFICATIONS

### PowerSno™

Universal CO<sub>2</sub> Spray Treatment System  
Model PSVP USTS

#### Plug-and-Spray System Includes:

- 1. CO<sub>2</sub> Composite Spray Generator:** All-in-one chassis equipped with main power on/off switch, adjustable ambient-temperature propellant gas thrust regulator and gauge (0-120 psi), and adjustable liquid CO<sub>2</sub> injection pressure regulator and gauge (0-1500 psi).
- 2. Spray Applicator:** Split coaxial single spray applicator (Micronizer™ SOLO).
- 3. Liquid CO<sub>2</sub> Supply Connection Kit:** CGA320-cylinder adaptor, hose, and 5-micron pre-filter for a high-pressure CO<sub>2</sub> cylinder (w/siphon tube), and supply hose(s) for one or more PowerSno spray systems.
- 4. Local or Remote Actuation:** 3-pin I/O connector and cable for footswitch (standard), spray trigger, or remote machine-robot actuation (24VDC contact closure).
- 5. Process Fluids Filtration:** Propellant and CO<sub>2</sub> (0.7/0.5-micron standard).



Micronizer™ Spray Applicators  
Shown Above: TRIAD



Footswitch Actuator

## REQUIREMENTS

<b>System Power (Electric and Pneumatic)</b>	110VAC - 50/60 Hz (24VDC PS), Air – 75-120 psi
<b>CO<sub>2</sub> Supply and Usage</b>	Liquid CO <sub>2</sub> , 830-950 psi, 10-25°C, 2-5 lbs/hr/nozzle
<b>Propellant Gas Supply and Usage</b>	CA, CDA or GN <sub>2</sub> , 70-120 psi, 3-6 scfm/nozzle
<b>Spray Actuation (Contact Closure)</b>	Footswitch, Spray Trigger, or Remote Cable Control
<b>Maximum Operating Temperature</b>	25°C (Liquid CO <sub>2</sub> Changes to scCO <sub>2</sub> above 31°C)
<b>Footprint</b>	12" (W) X 18.5" (D) X 20" (H) Console

## PERFORMANCE OPTIONS AND ACCESSORIES

- ✦ **Particle-Plasma:** Tantec Atmospheric Plasma System
- ✦ **Spray Quality Monitor:** LightSPEC™ Spray Quality Monitoring (SQM) System
- ✦ **Surface Quality Monitor:** Photoemission Tech Surface Quality Monitoring - *Clean-by-the-Number™* - System
- ✦ **Benchtop Robot:** Janome Cartesian or Universal Collaborative Robot
- ✦ **Ultrafiltration Filter:** 0.003 micron Stainless Steel Filters
- ✦ **Spray Applicators:** Cluster and Wide Spray Applicators, and Custom Spray Applicators
- ✦ **Treatment Cabinet:** HEPA-Exhausted Ionized Air Treatment System
- ✦ **MicroSno™ Module:** Satellite CO<sub>2</sub> Spray Module
- ✦ **Process Air Heater:** Wall-mounted 500-watt propellant heater

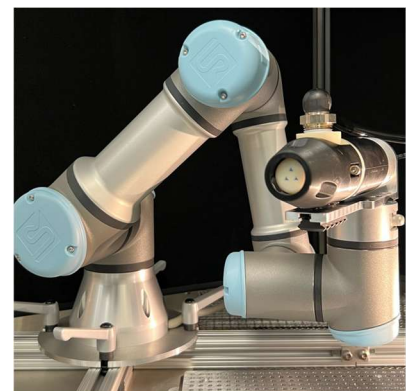

PRECISION CLEANING SCHEME

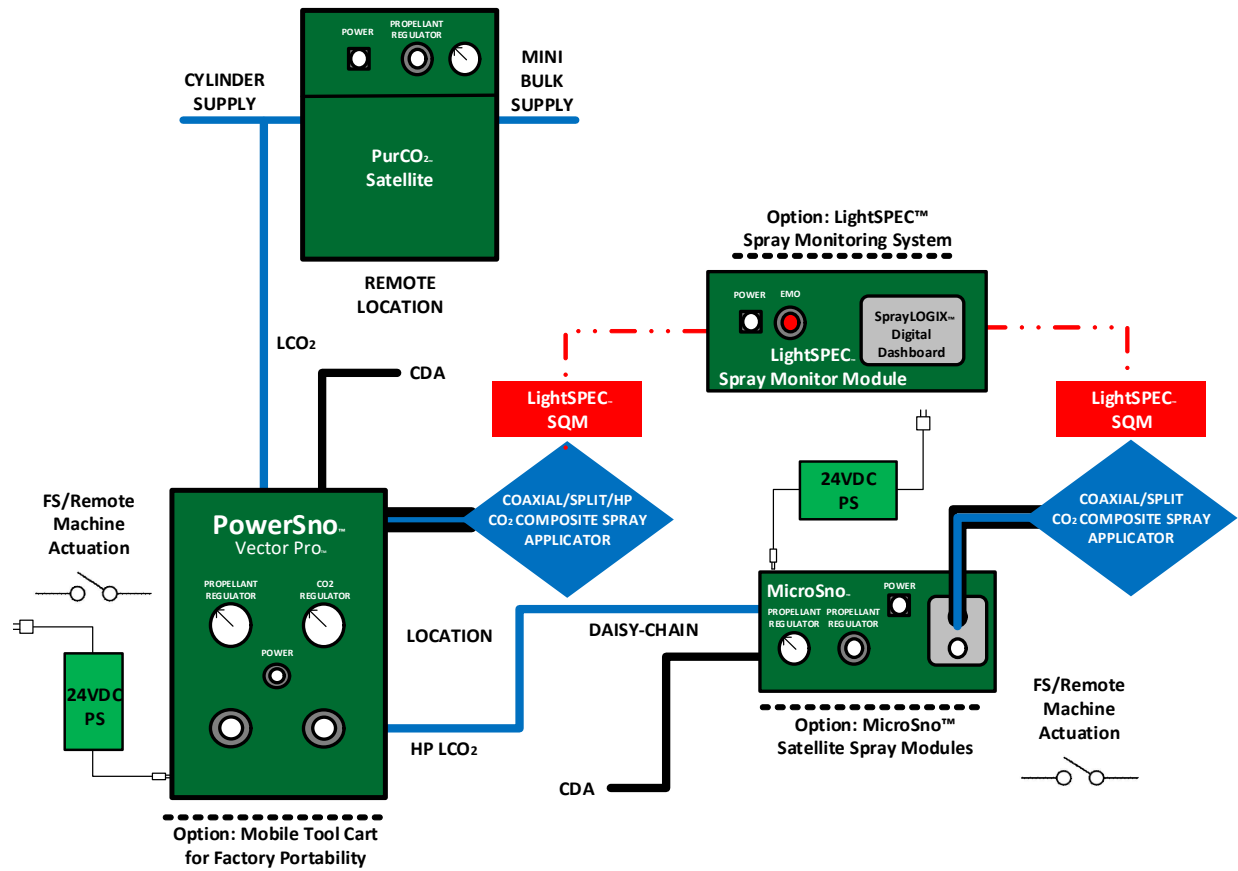



Clean Manufacturing, *Reimagined.*

clean  
imagineering™

**CLEANLOGIX™**  
a division of Clean Imagineering LLC

767 Hawthorne Avenue Unit B  
Ponderay, ID 83852 U.S.A.  
<https://www.cleanimagineering.com>  
[info@cleanimagineering.com](mailto:info@cleanimagineering.com)  
+1 (661) 430-6767

© Clean Imagineering LLC  
All Rights Reserved

Release Date: March 20, 2026

Tech Spec PowerSno USTS.PDF